

## Application



The general purpose sump float level switch provides reliable liquid level detection and is designed for the automation of pumps, specifically filling and draining of tanks, wells and reservoirs. The LV42 body is free of any irregularities, making it ideal for use in sewage water applications. The polypropylene body consists of a double airtight chamber with high-pressure melted polypropylene re-injection sealing to ensure a perfect seal against infiltration.



## Features

- ✓ Mercury-free self counter-weighted float switch
- ✓ Submersible polypropylene body and PVC cable for corrosive liquids
- ✓ 10 (3) A @ 250 VAC dry contact selectable NO or NC state via wiring selection
- ✓ Compatible with counter weights and cable hangers for simple installation

## Key Benefits

- ✓ Ideal for use in sewage water applications
- ✓ Float can wire directly to PLC/ SCADA or controller
- ✓ Counter-weighted float minimizes the effects of relay chatter
- ✓ Double-airtight chamber helps protect from debris infiltration

## Compatible Products

### Switch-Pro™ Remote Level Controller



**LC4X**

### Application

Available in general purpose classification, the level controller is offered in three configurations for pump and valve control. The LC40 accepts one level sensor input and provides one 10A relay. The LC41 accepts two level sensor inputs and provides one latching 10A relay for automatic fill or empty control. The LC42 accepts three level sensor inputs with one latching 10A relay output for automatic fill or empty control, and a second non-latching 10A relay for high level alarm or low level alarm. For field mount installation, add a single or dual indicator NEMA box.

### Switch-Pro™ Compact Level Controller



**LC1X**

### Application

The general purpose level controller is offered in two configurations for pump and valve control. The LC10 accepts one level sensor input and provides one 16A relay for high level control or low level control. The LC11 accepts two level sensor inputs and provides one latching 16A relay for automatic fill or empty control. The optional flash alarm brings attention to level alarm conditions. Package this level controller with our liquid level switch sensors and fittings.

### Specifications

Orientation: Vertical

Service: Compatible liquids, slurries

Contact type: SPDT (NO/NC)

Contact rating: 10 (3) A @ 250 VAC

Process temp.: F: -4° to 176°  
C: -20° to 80°

Pressure: 29 psi (2 bar)

Sensor rating: IP68

Sensor material: Polypropylene

Cable jack. mat.: PVC

Weight (housing): 2.4 lb (1.1 kg)

Weight (cable): 0.77 lb (21.27g) per foot

Classification: General purpose

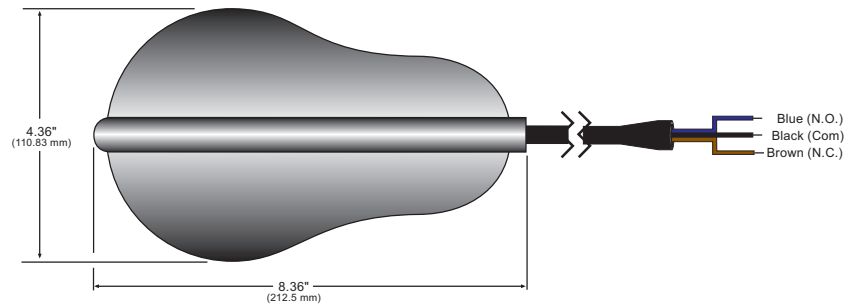

Compliance: CE

### Dimensions



### Accessories

For enhanced flexibility and performance, use these recommended accessories.

	P/N	Description
	LV49-7000	Counter Weight
	LV49-9000	Cable Hanger
	LD90-1000	Cable Enclosure, PP
	LD90-5000	Cable Enclosure, PVDF

### Ordering

LV42-7   1

Notes

**Cable length**  
20 20' of cable  
50 50' of cable