

Clamp-On Meter Models 511, 512 & 514

Fast 1ms Peak
capture of
inrush current



The AEMC® Models 511, 512 and 514 are general purpose professional clamp-on meters that measure up to the toughest standards. They are built into a rugged mechanical case and are designed using quality polycarbonate materials. These meters offer a complete set of measurement ranges and are in compliance with international safety and quality standards to ensure professional and reliable measuring tools. The Models 511 and 512 are Auto-Ranging and provide the best measurement range and resolution for troubleshooting. They also have a high resolution 40A range.

They measure AC Amps, AC Volts, as well as DC Volts, Ohms, Continuity (with beeper), Frequency (from V or A)

and have a Diode Test function. The Model 514 also uses Hall Effect sensor technology that provides both DC and AC current measurements to 1000A.

The Models 511, 512 and 514 are sized for comfortable, one-handed operation. The tapered and hooked jaw design facilitates maneuvering in crowded wiring and breaker panels, making it easy to select conductors. The jaw opening accommodates one 750MCM cable or two 350MCM cables. The large and easy-to-read 4000-count LCD features comprehensive user information symbols, such as low battery, polarity, overload, and an analog bargraph for easy trend readings. All models are equipped with a Data Hold function that freezes the measurement

for later viewing, Min/Max, and a fast 1ms Peak Hold function for capture of signals.

The Model 511 is average sensing and designed for traditional average responding electrical systems. The Models 512 and 514 are True RMS clamp-ons that provide RMS measurements for today's non-linear electrical environments.

All models include a pair of test leads (red/black with probe tips), 9V battery, soft carrying pouch and a user manual — ready to go!

Features

- Standard size, full function clamp-on meters
- 1000AAC or 1000AAC/DC current measurements
- 750VAC or 1000VDC volt measurements
- TRMS measurements (Models 512 and 514)
- Resistance measurements to 4000 Ω
- Continuity with beeper below 40 Ω
- Frequency measurements from V and A
- Diode test
- 1ms Peak function for fast capture of signals
- Hold function to “freeze” readings
- Push-button for easy ADC zeroing
- Large, easy-to-read 4000-count display
- 42-segment analog bargraph
- Includes test leads and soft carrying pouch

Applications

- Commercial, industrial, residential and HVAC troubleshooting
- Power panel, junction box and battery bank monitoring
- AC or DC motor testing
- Power plant troubleshooting
- Electrical testing and troubleshooting on traditional and non-linear loads, such as adjustable speed drives and computers



Specifications

MODELS	511 (Average Sensing)	512 (TRMS)	514 (TRMS)
AC AMPERES (Auto-Ranging)			
Measurement Range	0.05A to 1000A	0.05A to 1000Arms	0.05A to 1000Arms
Resolution	40A 400A 1000A	0.01A 0.1A 1A	0.01A 0.1A 1A
Accuracy	50 to 60Hz 60 to 500Hz	±1.9% of Reading ± 5cts ±1.9% of Reading ± 5cts	±1.9% of Reading ± 5cts ±2.5% of Reading ± 5cts
Overload Protection	40A 400A 1000A	800Arms 1500Arms 1500Arms	1200Arms 1200Arms 1200Arms
AC VOLTS			
Measurement Range	0.5V to 750V	0.5V to 750Vrms	0.5V to 750Vrms
Resolution	400V 750V	0.1V 1V	0.1V 1V
Accuracy	50 to 500Hz	±1.2% of Reading ± 5cts	±1.5% of Reading ± 5cts
Input Impedance		10MΩ	10MΩ
Overload Protection		1000Vrms	1000Vrms
DC AMPERES			
Measurement Range	–	–	1A to 1000A
Resolution	40A 400A 1000A	– – –	0.01A 0.1A 1A
Accuracy			±2.5% of Reading ± 10cts
Overload Protection			1200Arms
DC VOLTS			
Measurement Range	0.2V to 1000V	0.2V to 1000V	0.2V to 1000V
Resolution	400V 1000V	0.1V 1V	0.1V 1V
Accuracy		±0.75% of Reading ± 2cts	±1% of Reading ± 2cts
Input Impedance		10MΩ	10MΩ
Overload Protection		1200Vrms	1000Vrms
RESISTANCE-OHMS (Ω)			
Measurement Range	0.2Ω to 4000Ω	0.2Ω to 4000Ω	0.2Ω to 4000Ω
Resolution	400Ω 4000Ω	0.1Ω 1Ω	0.1Ω 1Ω
Accuracy		±1% of Reading ± 2cts	±1% of Reading ± 2cts
Max. Test Voltage		3Vdc	3Vdc
Overload Protection		600Vrms	600Vrms
DIODE			
Test Current		0.6mA	1.7mA max
Overload Protection		600Vrms	600Vrms
Open Circuit Voltage		3Vdc	3Vdc
CONTINUITY (•))			
Beeper Activation		<40Ω	<40Ω
Max. Test Voltage		3Vdc	3Vdc
Overload Protection		600Vrms	600Vrms
FREQUENCY (Hz)			
CURRENT INPUT Range	4kHz 10kHz	1Hz Resolution –	1Hz Resolution 10Hz Resolution
Accuracy	20Hz to 10kHz	±0.1% of Reading ± 1ct	±0.1% of Reading ± 1ct
Min. Input Signal	4kHz 10kHz	2Arms –	2Arms 5Arms
VOLTAGE INPUT Range	4kHz 10kHz	1Hz Resolution 10Hz Resolution	1Hz Resolution 10Hz Resolution
Accuracy	20Hz to 10kHz	±0.1% of Reading ± 1ct	±0.1% of Reading ± 1ct (10 to 10kHz)
Min. Input Signal	4kHz 10kHz	5Vrms 5Vrms	5Vrms 10Vrms

Specifications

MODELS	511 (Average Sensing)	512 (TRMS)	514 (TRMS)
GENERAL			
Digital Display	3¾ digits LCD display, 4000-count (max. reading 3999)		
Analog Display	Fast 42-segment analog bargraph display		
Symbol and Scale Range	Automatic according to range and input signal		
Polarity	■ Displayed when negative signal applied to input		
Overload	⊖⊕ Displayed when input signal exceeds range		
Sample Rate	2 samples/sec for the digital display, 20 samples/sec for the analog bargraph		
Power Supply	9V, NEDA 1604 or 6F22 or 006P		
Auto-Off	30 minutes		
Low Power Indication	⊖⊕ Displayed when the battery is below the required voltage		
Jaw Opening Size Ø	1.575" (40mm) – facilitates 750MCM cable or two 500MCM cables		
Dimension	9.53 x 2.60 x 1.42" (242 x 66 x 36mm)		
Weight	14.10 oz (400g) with batteries		
ENVIRONMENTAL			
Altitude	2167 ft (2000m) max.		
Operating Temperature	511/512: 32° to 104°F (0° to 40°C), <80% RH, non-condensing 514: -14° to 122°F (-25 to 50°C), 80% RH, non-condensing*		
Storage Temperature	-14° to 140°F (-25° to 60°C), < 80% RH, battery removed		
Pollution Degree	2		
SAFETY			
Safety Rating	EN 61010, 600V, CAT III, EN 61010, 1000V, CAT II		
CE Mark	Yes		

*NOTE: If the meter is to be used below 32°F (0°C), we suggest that the battery be replaced to ensure proper results.

Construction

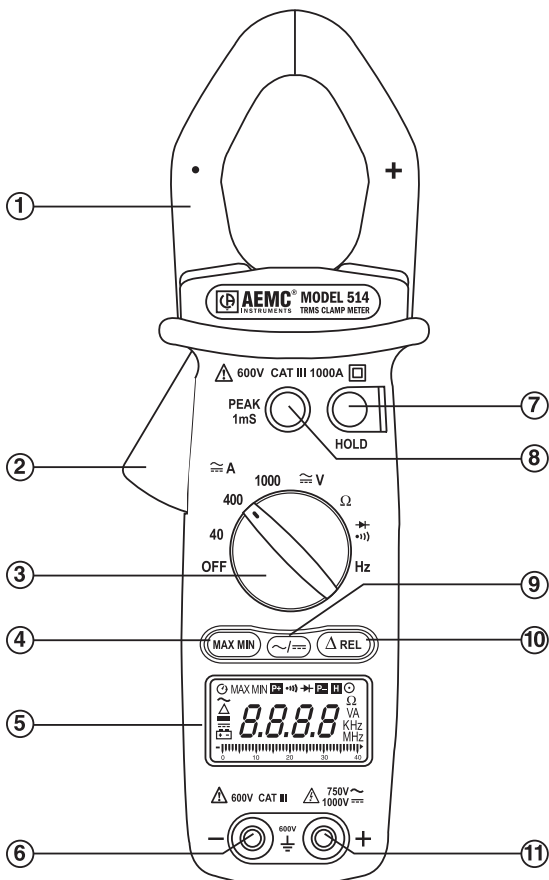

Model 514

Function	Model 511	Model 512	Model 514
TRMS	-	✓	✓
1000Aac	✓	✓	✓
1000Adc	-	-	✓
750Vac	✓	✓	✓
1000Vdc	✓	✓	✓
Resistance	✓	✓	✓
Diode	✓	✓	✓
Continuity	✓	✓	✓
Beeper	✓	✓	✓
Frequency	✓	✓	✓
Bargraph	✓	✓	✓
Hold	✓	✓	✓
Min/Max	✓	✓	✓
1ms Peak	✓	✓	✓
Push button DC Zero	-	-	✓

1. Data hold button
2. 1ms Peak hold button
3. AC/DC select button
(Model 514)
Range button
(Models 511 and 512)
4. Relative button and
ADC zero
5. Positive (Red) + input jack
6. COM (Black) – input jack
7. LCD display
8. Maximum/Minimum
button
9. Rotary range selector
switch
10. Lever for jaw opening/
closing
11. Jaw assembly

Selection Chart



MODEL	511	512	514
Catalog No.	2117.67	2117.68	2117.70
Type	AC	AC TRMS	AC/DC TRMS
AC Current	0.05 to 1000A	0.05 to 1000A	0.05 to 1000A
AC Voltage	0.5 to 750V	0.5 to 750V	0.5 to 750V
DC Current	–	–	1A to 1000A
DC Voltage	0.2 to 1000V	0.2 to 1000V	0.2 to 1000V
Resistance (Ω)	4000 Ω	4000 Ω	4000 Ω
Continuity	<40 Ω	<40 Ω	<40 Ω
Frequency (Hz)			
Current	20Hz to 10kHz	20Hz to 10kHz	20Hz to 10kHz
Voltage	10Hz to 10kHz	10Hz to 10kHz	10Hz to 10kHz
True RMS	–	Yes	Yes
Jaw Size	1.58" (40mm)	1.58" (40mm)	1.58" (40mm)
Dimension	9.53 x 2.60 x 1.42"	9.53 x 2.60 x 1.42"	9.53 x 2.60 x 1.42"

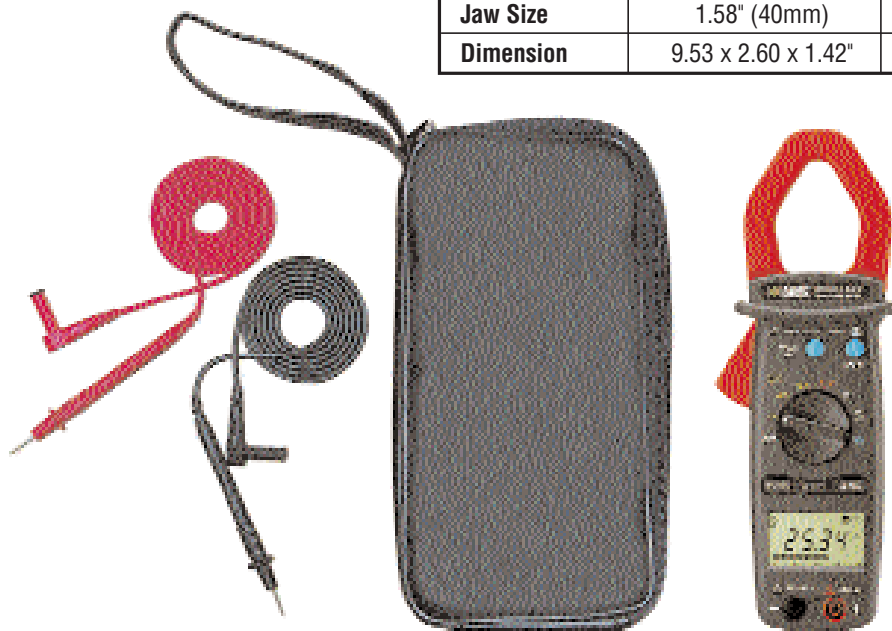

Models 511, 512 & 514 includes a pair of test leads and soft carrying case

ORDERING INFORMATION

CATALOG NO.

- Clamp-on Meter Model 511 (AC, 1000A_{AC}, 600V_{AC/DC}, Ohms, Continuity) **Cat. #2117.67**
- Clamp-on Meter Model 512 (TRMS, 1000A_{AC}, 600V_{AC/DC}, Ohms, Continuity) **Cat. #2117.68**
- Clamp-on Meter Model 514 (AC/DC, TRMS, 1000A_{AC/DC}, 600V_{AC/DC}, Ohms, Continuity) **Cat. #2117.70**

All clamp-on meters are supplied with a pair of test leads (red/black with probe tips), batteries, soft carrying case and a user manual

Contact Us

United States & Canada:

Chauvin Arnoux®, Inc.
d.b.a. AEMC® Instruments
200 Foxborough Blvd.
Foxborough, MA 02035 USA
(508) 698-2115 • Fax (508) 698-2118
www.aemc.com

Customer Support – for placing an order, obtaining price & delivery:
customerservice@aemc.com

Sales Department – for general sales information:
sales@aemc.com

Repair and Calibration Service – for information on repair & calibration, obtaining a user manual:
repair@aemc.com

Technical and Product Application Support – for technical and application support:
techinfo@aemc.com

Webmaster – for information regarding www.aemc.com:
webmaster@aemc.com

South America, Central America, Mexico, Caribbean, Australia & New Zealand:

Chauvin Arnoux®, Inc.
d.b.a. AEMC® Instruments
15 Faraday Drive
Dover, NH 03820 USA
(978) 526-7667 • Fax (978) 526-7605
export@aemc.com
www.aemc.com

All other countries:

Chauvin Arnoux SCA
190, rue Championnet
75876 Paris Cedex 18, France
33 1 44 85 45 28 • Fax 33 1 46 27 73 89
info@chauvin-arnoux.com
www.chauvin-arnoux.com